



## General Features

- Silica gel technology for longer cycle life and better performance at cold ambient temperatures.
- Special sheet separator and colloidal or foamed silica.
- Deep discharge cycle increased by 50% as compared with the AGM battery.
- High reliability and quality.
- Excellent recovery from deep discharge.
- Living up prevailing standards.

## Specification

Nominal Voltage	12V
Number of cell	6
Design Life	10 years
Nominal Capacity 77°F(25°C)	
20 hour rate(4.0A, 10.5V)	80Ah
10 hour rate(7.6A, 10.5V)	76Ah
5 hour rate(13.6A, 10.5V)	68.0Ah
1 hour rate(52.8A, 9.6V)	52.8Ah
Internal Resistance	
Fully Charged battery 77°F(25°C)	5.2mOhms
Self-Discharge	
3% of capacity declined per month at 20°C(average)	
Operating Temperature Range	
Discharge	-20~60°C
Charge	-10~60°C
Storage	-20~60°C
Max. Discharge Current 77°F(25°C)	800A(5s)
Short Circuit Current	2000A
Charge Methods: Constant Voltage Charge 77°F(25°C)	
Cycle use	14.4-14.7V
Maximum charging current	24A
Temperature compensation	-30mV/°C
Standby use	13.6-13.8V
Temperature compensation	-20mV/°C

## Dimensions and Weight

Length(mm / inch)	258 / 10.16
Width(mm / inch)	166 / 6.54
Height(mm / inch)	206 / 8.11
Total Height(mm / inch)	211/8.31
Approx. Weight(Kg / lbs)	27.0/59.5
Standard Terminal	I

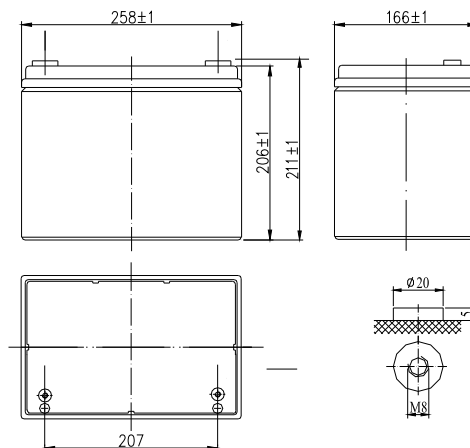

## Discharge Constant Current (Amperes at 77°F25°C)

End Point Volts/Cell	5min	10min	15min	30min	1h	3h	5h	10h	20h
1.60V	280	192	140	84.0	52.8	21.8	14.5	7.95	4.66
1.65V	252	175	136	81.6	52.7	21.7	14.1	7.82	4.62
1.70V	239	168	131	80.0	52.5	21.6	13.8	7.77	4.56
1.75V	212	156	124	78.4	52.0	21.6	13.6	7.60	4.00
1.80V	192	144	118	76.0	51.3	21.5	13.2	7.50	4.43

## Discharge Constant Power (Watts at 77°F25°C)

End Point Volts/Cell	5min	10min	15min	30min	1h	3h	5h	10h	2h
1.60V	461	318	248	158	104	41.9	29.2	16.9	33.8
1.65V	437	314	245	155	100	41.8	29.0	16.7	33.6
1.70V	408	306	241	151	98.0	41.7	28.9	16.5	33.4
1.75V	380	286	227	147	97.0	41.2	28.8	16.3	33.2
1.80V	341	266	213	143	95.3	40.7	28.4	16.0	32.9

